

SmartRail Modular Handrail System



949-346-3456

www.thesmartlightingcompany.com
sales@thesmartlightingcompany.com

The SmartRail Modular Handrail System

- SmartRail is customized based on your project requirements and is optimized for new or retrofit applications.
- Modular systems: parts are shipped and assembled onsite with detailed installation instructions to build your railing system.
- SmartRail is shipped in 16'4" lengths and cut in the field to size.
- LEDs are made with a UL listed, high-quality silicone to ensure: their impact and weather resistance, that they produce a strong output that does not yellow over time, and they maintain their flexibility.
- Installation should only be performed by a handrail installer or skilled contractor. Once installation is completed, the electrician can make the connection to the power supplies.



SmartRail Illuminated System Types

Round Stainless 316 - 1.9" and 1.66"



Round Wood - 1.66"



Square Stainless 316 - 1.57"



Rectangle Aluminum



Round SmartRail Mounting Styles

- Cap rail available for 1.9" and 1.66" diameter
- Wall or post mounted (Round or Square posts).
- Many options for creating your rail such as adjustable angles, wall returns, and end caps.
 - Post mount – Embedded
 - Post mount – Surface
 - Post mount – Flange
 - Wall mount
 - Glass mount



Wood Wood Cap rail - 1.66"

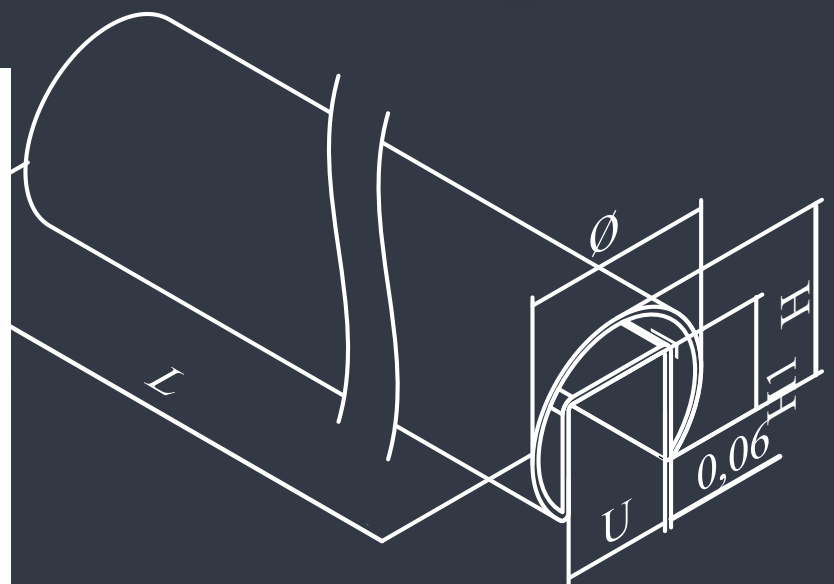

Round Rail options

Handrail Mounting and Bracket options



Adjustable Post Mount



Fixed Post Mount



Wall Mount Bracket



Glass Mount Bracket

Corner and Stairway options

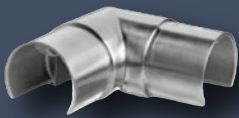

90° Connectors



Adjustable Connectors for Stairs

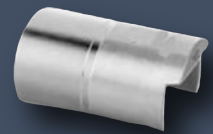

Tube to Cap Rail Connectors

End and Return options



End Fitting



End Cap



Wall Return

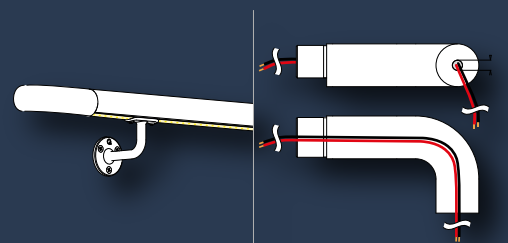

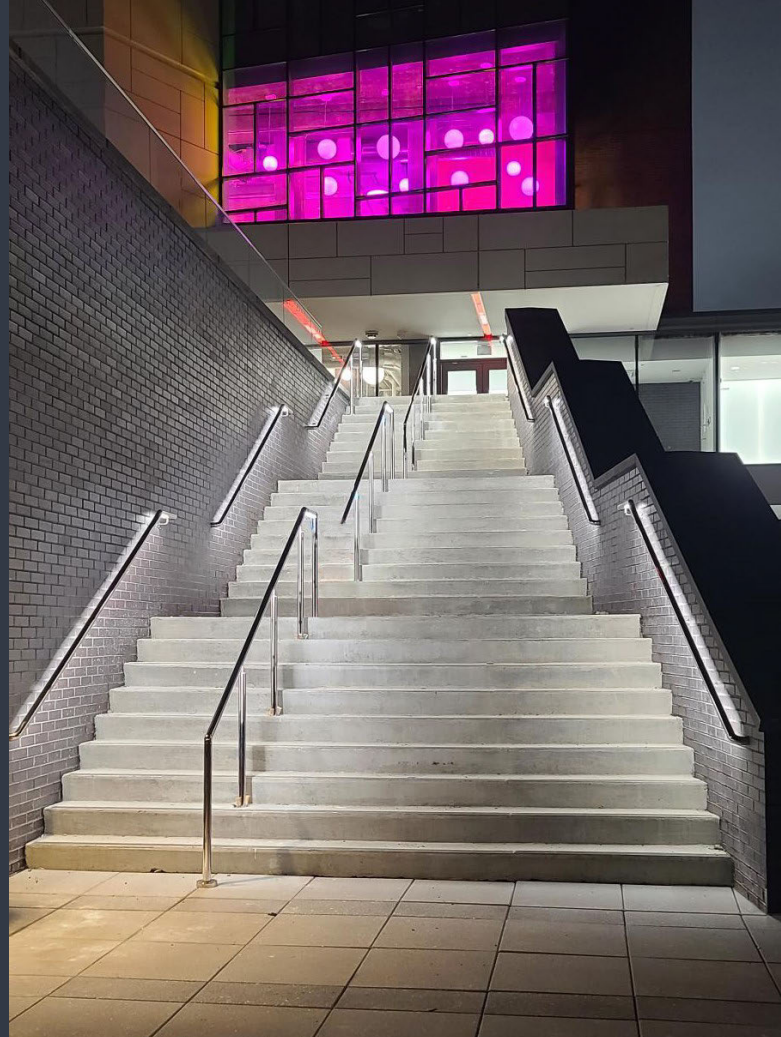

Round SmartRail Applications





Residential

Round WoodRail Applications



Elevator

Square SmartRail Mounting Styles

- Cap rail available in 1.57" x 1.57" diameter
- Wall or post mounted (round or square posts).
- Many options available for creating your rail such as adjustable angles, wall returns, and end caps.
 - Post mount – Embedded
 - Post mount – Surface
 - Post mount – Flange
 - Wall mount
 - Glass mount

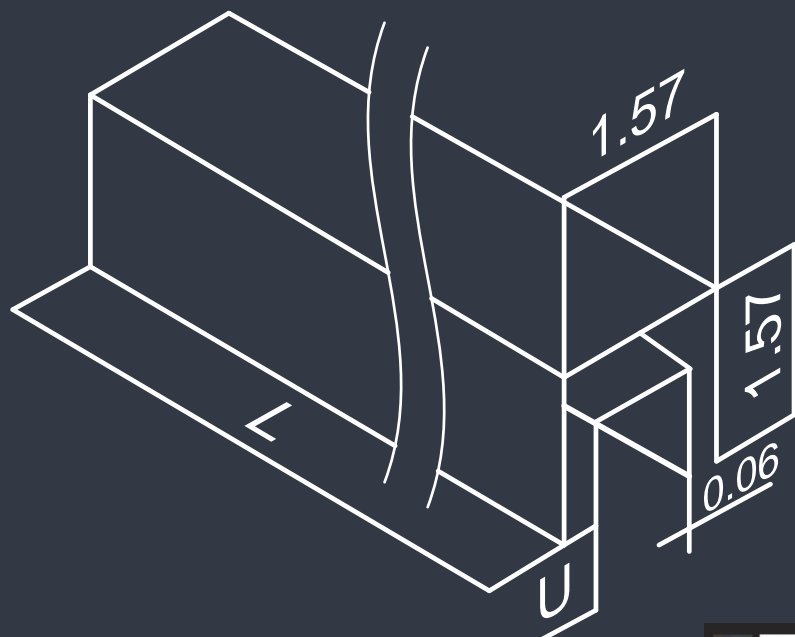
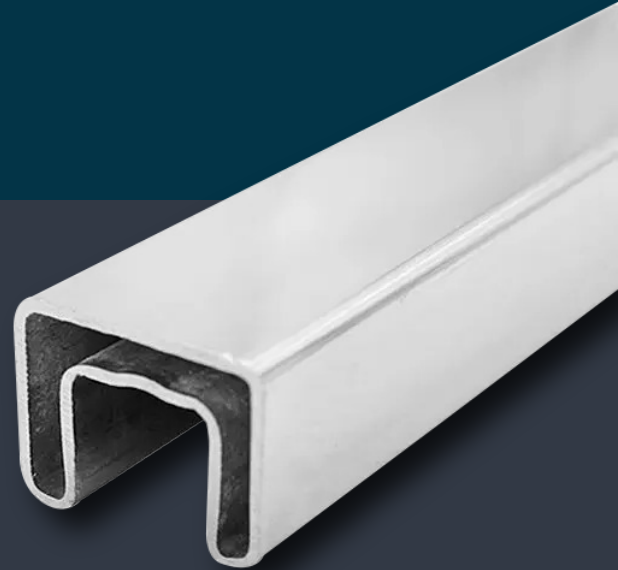

Square rail options

Handrail Mounting and Bracket options



Adjustable Post Mount



Fixed Post Mount



Post Mount Bracket

Corner and Stairway options

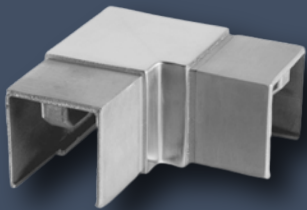

90° Connectors

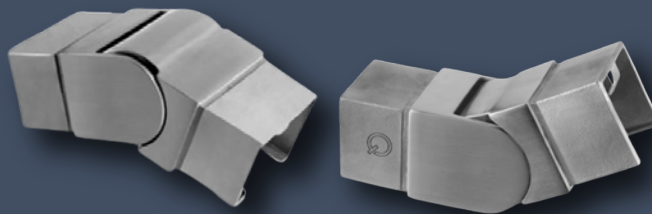

Adjustable Connectors for Stairs

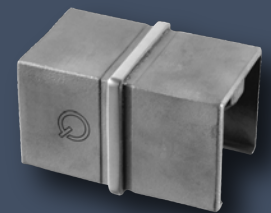

Tube to Cap Rail Connectors

End and Return options



End Fitting



End Cap



Square SmartRail Applications

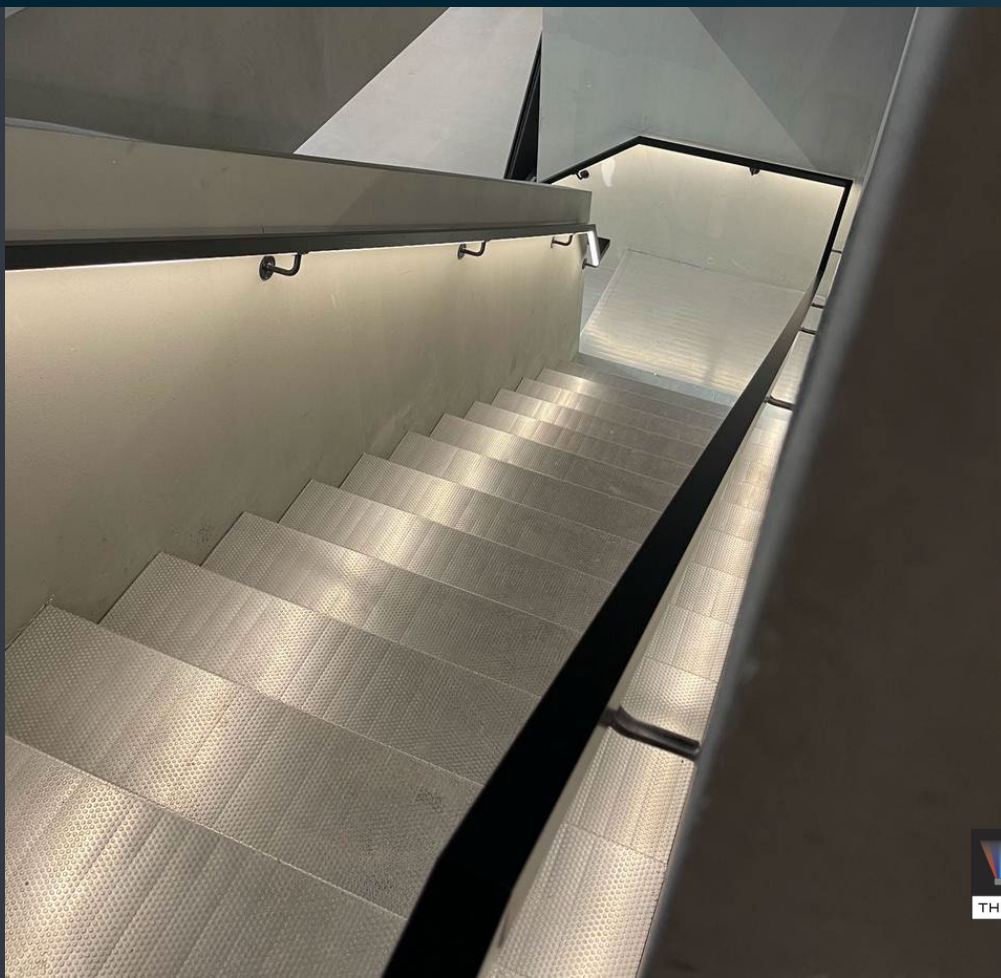

Rectangle SmartRail Mounting Styles

- Cap rail available in 2.56"x1.57" diameter
- Glass mounted only (glass by others)
- Many different components available for creating your unique and customized rail system

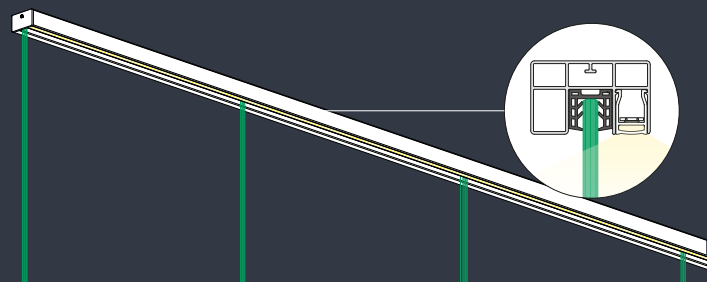
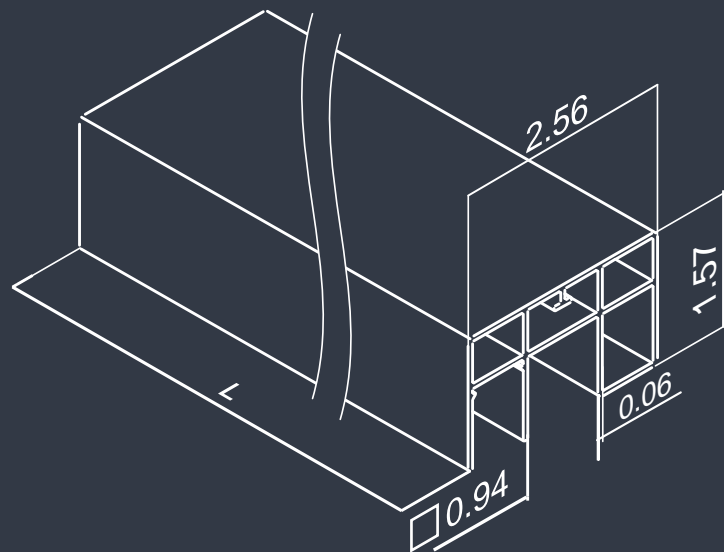

SmartRail Infill Options

Cable infill



Bar infill



Glass clamps for glass infill



SmartRail Technical Drawings

Upon ordering, we create drawings for your specific project showing each section with all the parts; we make sure you know how to put it together! Our customized installation instructions ensure easy and accurate field installation.

POST MOUNTED STAIRWAY EXAMPLE

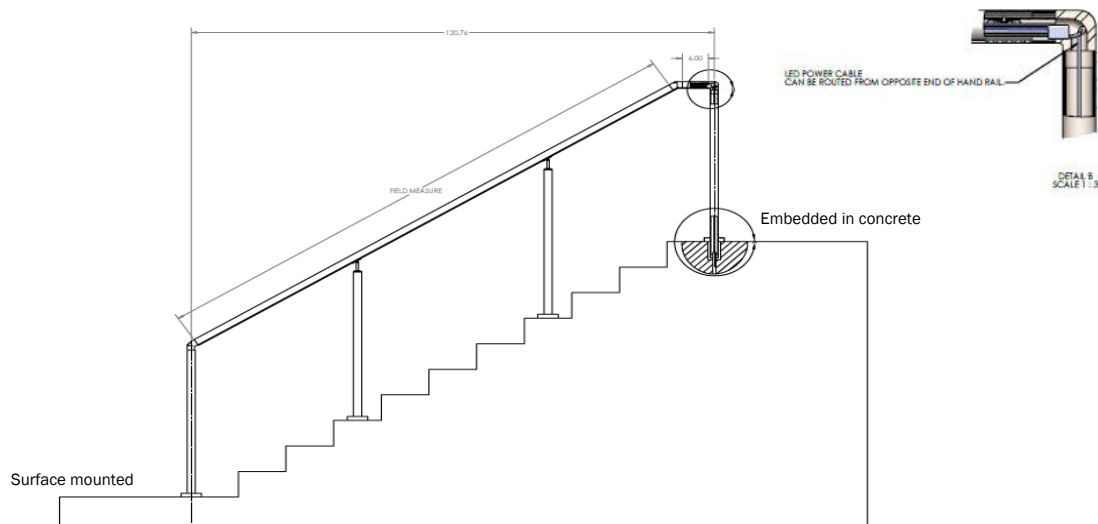

WALL MOUNTED STAIRWAY EXAMPLE

